

The QOM Series is designed specifically to power outdoor low voltage lighting systems. The QOM features two taps on the primary side to recover dimmer losses and four taps on the secondary side for multiple load distances. The QOM is UL Listed for indoor and outdoor use as well as being suitable for wet locations.

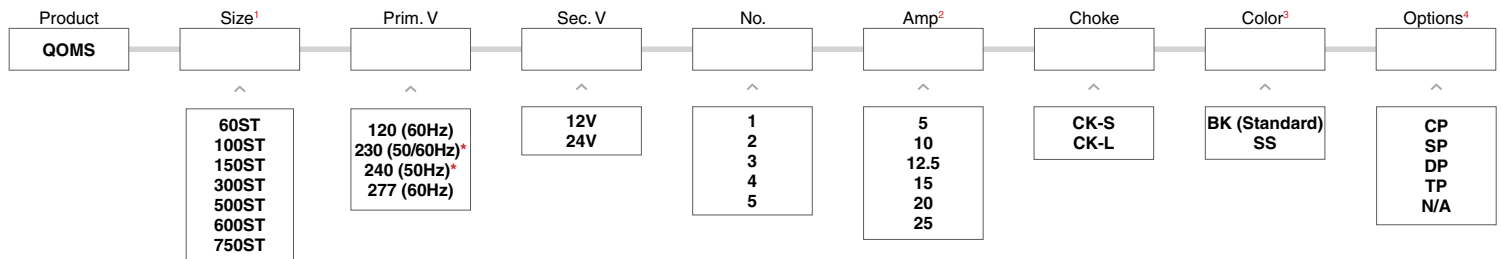

Part Number Builder



* Not standard, call factory for pricing

Technical Information

¹ Size

Size	Max Load (Watts)	PSC Efficiency	Max PSC Rating (Watts)	Max PSC Rating (VA)	Max Prim Amps @ 120V	Max Prim Amps @ 277V
60ST	60W	92%	66	79	0.66 A	0.28 A
100ST	100W	92%	108	135	1.1 A	0.48 A
150ST	150W	92%	163	200	1.7 A	0.70 A
300ST	300W	93%	322	400	3.4 A	1.5 A
500ST	500W	93%	538	670	5.6 A	2.4 A
600ST	600W	95%	632	800	6.7 A	2.9 A
750ST	750W	95%	789	1000	8.4 A	3.6 A

² Secondary Breaker Amperage

Amps	Max 12V Load	Max 24V Load
5	60W	120W
10	120W	240W
12.5	150W	300W
15	180W	360W
20	240W	480W
25	300W	600W

³ Color

BK Black Powder Coat Finish (Standard)
SS 316 Marine Grade Stainless Steel

⁴ Options

CP Cord & Plug
SP Switch Plate
DP Dimmer Plate
TP Timer Plate

Choke

CK-S 60W-300W
CK-L 500W-750W



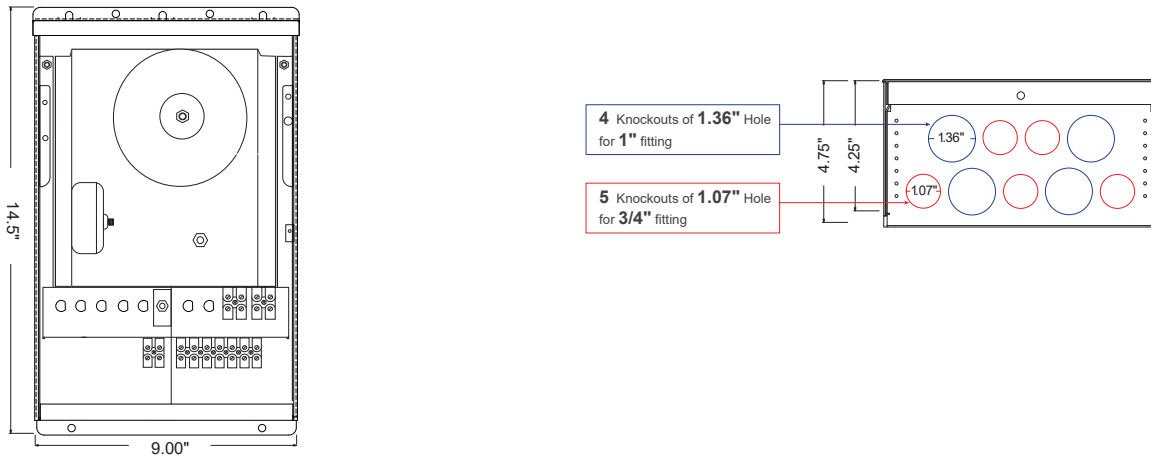

Housing

- 18-gauge welded steel enclosure: 9.0"W X 14.5"L X 4.75"D
- Knockouts: 9

Multi-Volt & Taps

Tap Options (in order from TAP1 to TAP5):

12V: 12, 13, 14, 15V

24V: 24, 25, 26, 27V

- Loads may be connected to one (1) of the primary taps up to the full watt rating of the PSC.
- The advantage is that loads at varying distances from the PSC can be tapped on different taps to recover voltage drop, allowing you to get the correct voltage at your load and produce between 85%-100% light output. (See Q-TRAN Voltage drop Calculator)
- Secondary Circuit Protection: 1-5 magnetic circuit breakers
- No derating required

Toroidal Choke

Q-Tran's standard choke, or "debuzzing coil" reduces noise when dimming and helps negate in-rush current that is prevalent with LED loads. It allows for quiet operation and eliminates nuisance tripping.

- | | |
|---|---|
| <ul style="list-style-type: none"> • Landscape lighting power unit • Suitable for damp and wet locations • Suitable for use with submersible luminaires or submersible pumps • Suitable for indoor/outdoor use • UL 1838 & 2108 listed | <ul style="list-style-type: none"> • Use dimmers rated for magnetic low voltage load with neutral wire • Isolation toroidal transformer • 50/60 cycle • CSA C22.2 No. 250.0-08 & 250.7-07 • Made in the U.S.A. |
|---|---|

INSTALLATION

QOMS/QOMD



QOMS 60W-750W

1 CONTROL ZONE

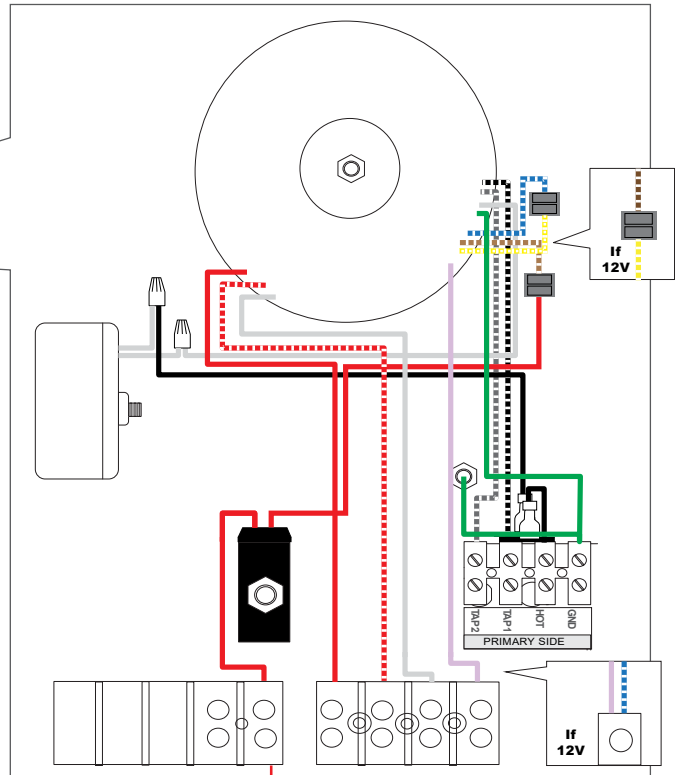
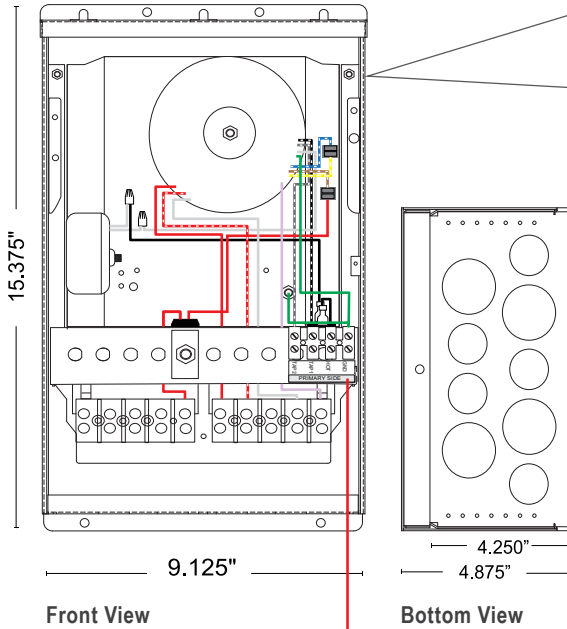

PRIMARY Line Voltage

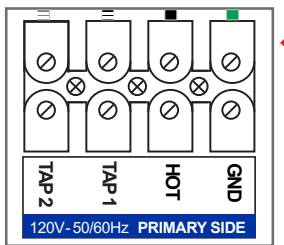

Land Neutral
 Land Hot
 Land Ground

Chose either tap 1 (switch) or 2 (dimmer; long primary run or low input voltage (115V or less))

*Must test all voltage readings with a True RMS Voltage Meter when controlled by a dimmer. Do not exceed secondary voltage!

SECONDARY Low Voltage

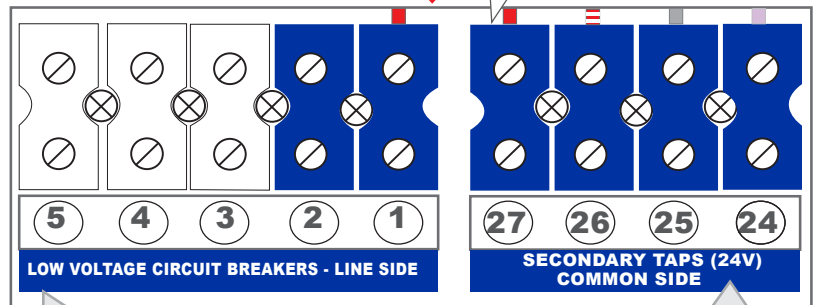

*Up to 5 Sec. Breakers can be used

BKR	COLOR	12V	24V
5 A	Orange	60w	120w
10 A	Red	120w	240w
12.5 A	Yellow	150w	300w
15 A	Yellow	180w	360w
20 A	Blue	240w	480w
25 A	Purple	300w	600w

Step 1.

Connect line side or "hot" side of the low voltage connection. Start with position # 1.

* Repeat step 1 & 2 for every new lead connection.

Step 2.

Connect common side to one of the low voltage terminal blocks.



L.V. Secondary feeds go to a 85 AMP rated terminal block. Each terminal is UL listed to have the following capacity:

6	#14
4	#12
4	#10
2	#8

*For longer runs you may need to go to a higher tap & or larger wire gauge on secondary side.

INSTALLATION

QOMS/QOMD



QOMD 60W-300W

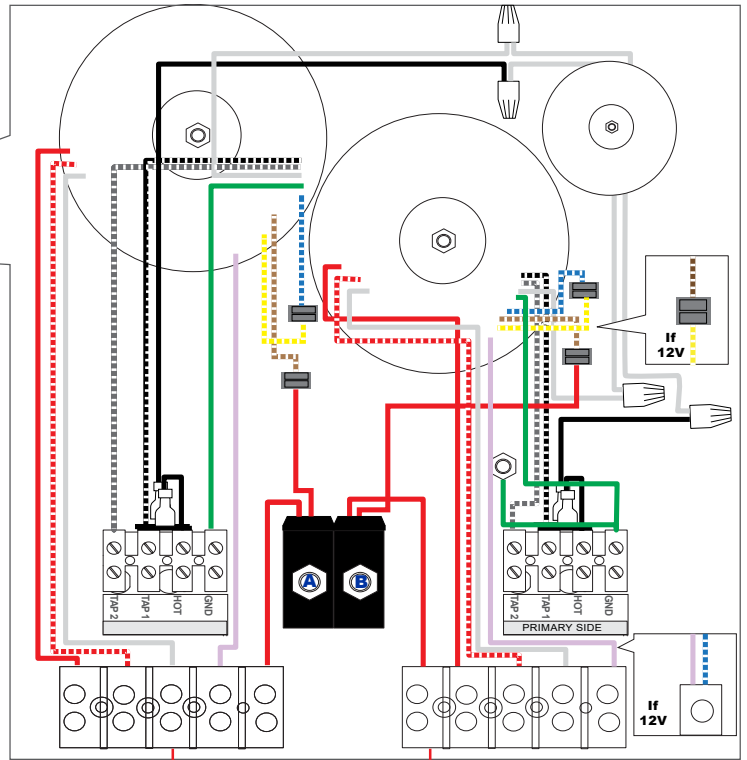
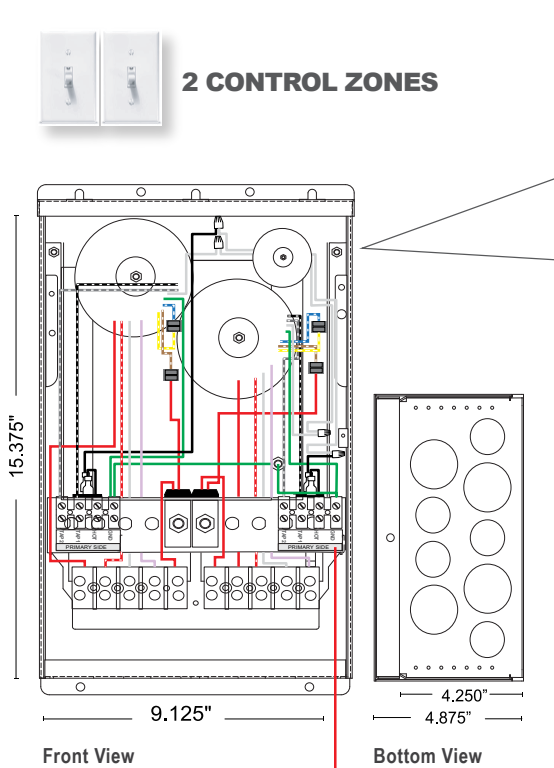

PRIMARY Line Voltage

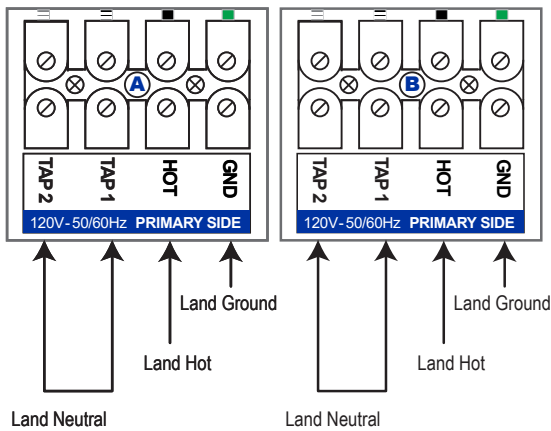

SECONDARY Low Voltage

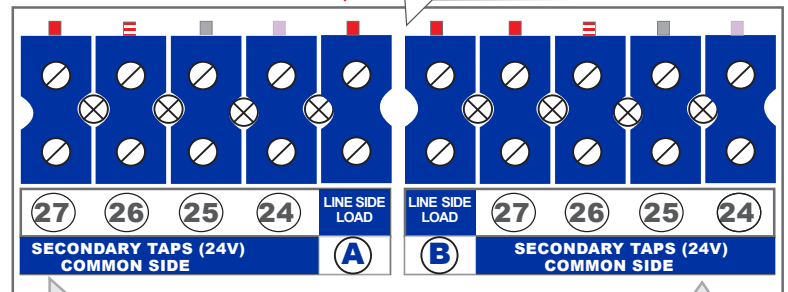

If 12V Taps are 12V, 13V, 14V, 15V

Chose either tap 1 (switch) or 2 (dimmer; long primary run or low input voltage (115V or less))

*Must test all voltage readings with a True RMS Voltage Meter when controlled by a dimmer. Do not exceed secondary voltage!

*Up to 5 Sec. Breakers can be used

BKR	COLOR	12V	24V
5 A	Orange	60w	120w
10 A	Red	120w	240w
12.5 A	Yellow	150w	300w
15 A	Yellow	180w	360w
20 A	Blue	240w	480w
25 A	Purple	300w	600w

Step 1.

Connect line side or "hot" side of the low voltage connection. Start with position # 1.

* Repeat step 1 & 2 for every new lead connection.

Step 2.

Connect common side to one of the low voltage terminal blocks.

L.V. Secondary feeds go to a 85 AMP rated terminal block. Each terminal is UL listed to have the following capacity:

6	#14
4	#12
4	#10
2	#8

*For longer runs you may need to go to a higher tap & or larger wire gauge on secondary side.

INSTALLATION

QOMS/QOMD



Wiring Diagram

120V (60Hz) - 12/24V

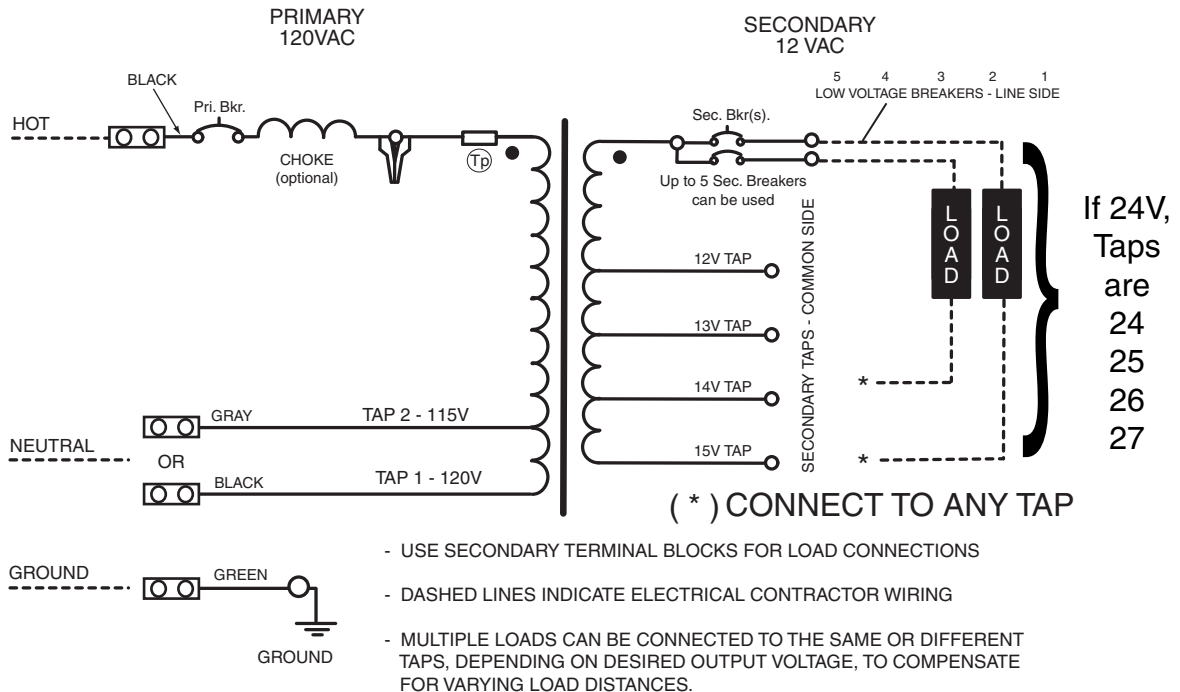

230V (50Hz) - 12/24V-CE 277V (60Hz) - 12/24V

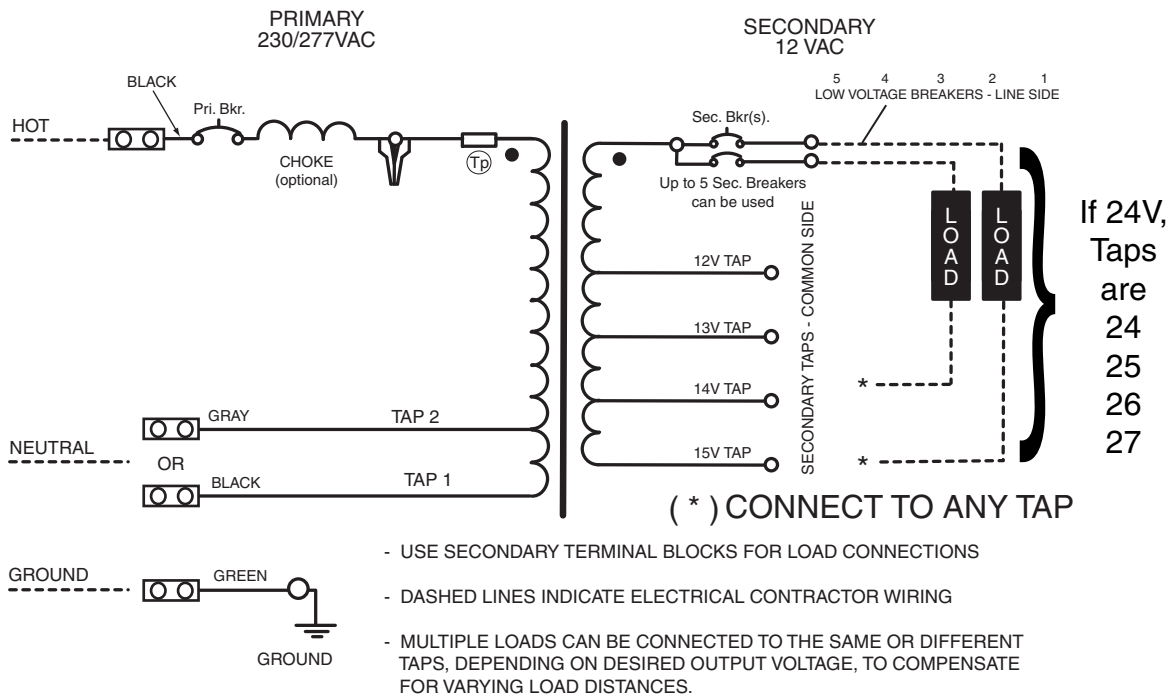

INSTALLATION

QOMS/QOMD



Selecting the Right Tap

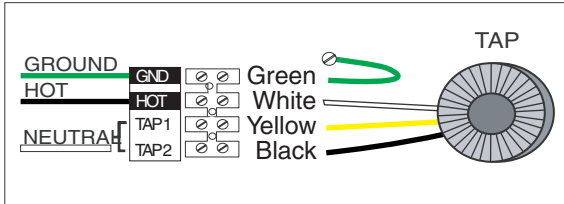

Conclusion:

With a simple field adjustment, the contractor was able to recover his voltage drop and light output by switching from Tap 12 to Tap 15.

A 12V Lamp Operating at 10V = 50 % Light Output!

Rating	Excellent	Good	Poor	Bad	Very Bad
Light Output	100%	85%	69%	57%	47%
Lamp Volts	24.0V	22.8V	21.6V	20.4V	19.2V
Voltage Drop	0%	-5%	-10%	-15%	-20%
Lamp Volts	12.0V	11.4V	10.8V	10.2V	9.6V
Light Output	100%	85%	69%	57%	47%
Rating	Excellent	Good	Poor	Bad	Very Bad

The Impact of Voltage Drop on Light Output

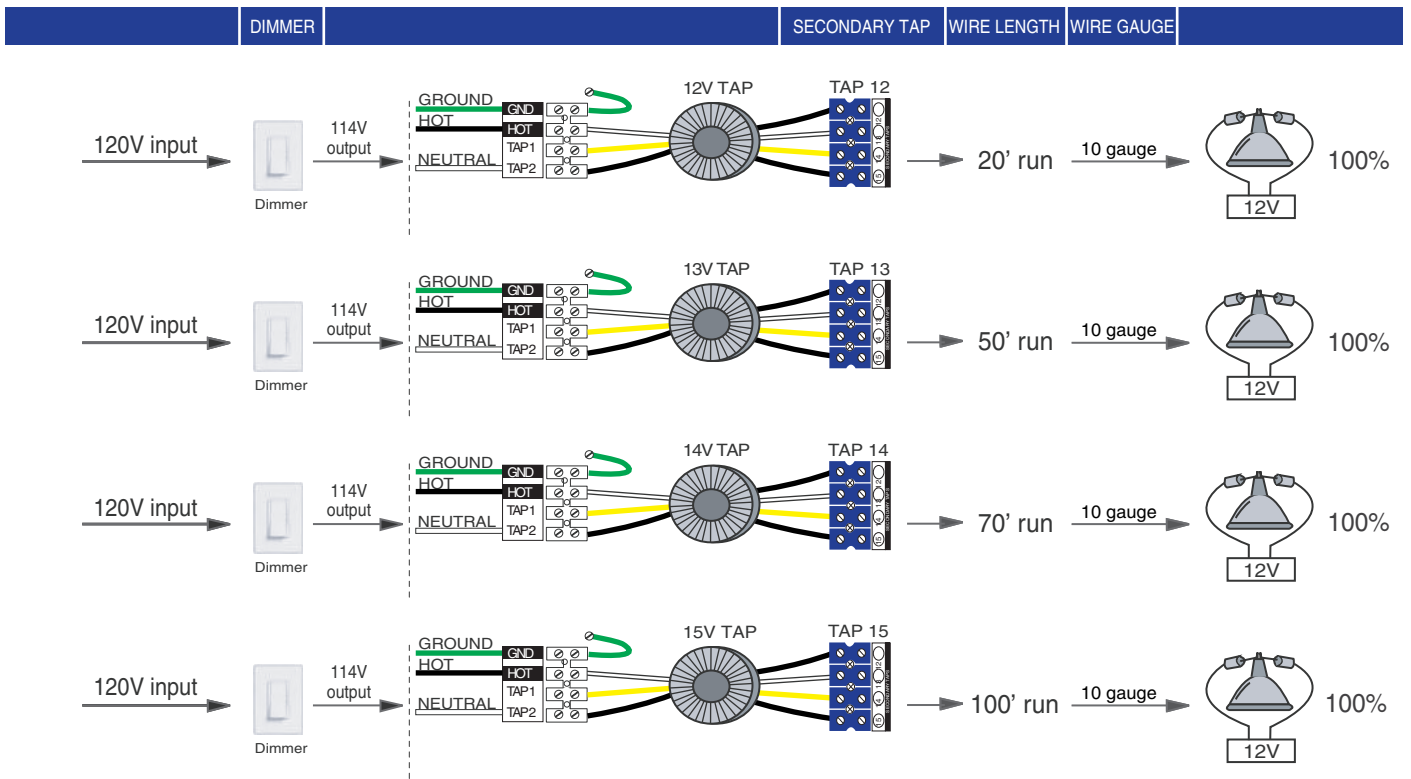

*For longer runs you may need to go to a higher tap & or larger wire gauge on secondary side.

* Use a True RMS Volt Meter when a dimmer is used.
(RMS = Root Mean Squared)

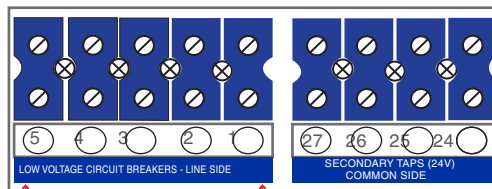

The "line side" of the load is connected to secondary circuit breakers.
[4 AMP - 25 AMP]

INSTALLATION

QOMS/QOMD



Warnings

WARNING

FOR CONDUIT CONNECTION RISK OF ELECTRIC SHOCK.

Install power unit 5 feet (1.5 m) or more from the pool or spa and 10 feet (3.05 m) or more from a fountain. Where the power unit is installed within 10 feet (3.05 m) of a pool or spa, connect unit to GFCI protected branch circuit.

FOR POWER SUPPLY CORD CONNECTION RISK OF ELECTRIC SHOCK.

Install power unit 5 feet (1.5 m) or more from the pool, spa, or fountain. Where the power unit is installed (a) indoors within 10 feet (3.05 m) of a pool, spa, or fountain or (b) outdoors, connect power unit to a receptacle protected by a GFCI.

RISK OF FIRE. If installation requires running wire through a building structure, special wiring methods are needed. Contact a qualified electrician.

OUTDOOR CORD - connected unit shall be connected to a GFCI protected hooded flush type cover plate receptacle marked "Wet Location."

DO NOT USE EXTENSION CHORDS.

The main Secondary Wiring is intended for shallow burial - less than 6 inches (152 mm) For Supply connections use wire rated for at least 60C.

* To order additional lengths of wire for connection in the secondary, contact your local distributor or Q-Tran at 203-367-8777 and inquire about Q-Wire.

For model series:

QOM-60, QOM-100, QOM-150, QOM-300, QOM-500, QOM-600, QOM-750, QOM-2X150, QOM-2X300 and QOM-150/300, all field installed conductors, both primary and secondary, shall have insulation suitable for the highest voltage potential of the equipment.

WIRE TYPE	PRI. WIRE COLOR	BREAKER	MINIMUM AWG	12V
HOT	BLACK	5A	14	60W
NEU (TAP 1)	RED	10A	14	120W
NEU (TAP 2)	ORANGE	15A	14	180W
GROUND	GREEN	20A	12	240W
		25A	10	300W

QOM						
Model	Input Voltage (V)	Input Current (A)	Frequency	Nominal Output Voltage (VDC)	Max Output Wattage (W)	
● QOM-60	120 / 277	.56 / .25	50/60	12/24	60	
● QOM-60X2	120 / 277	1.12 / .49	50/60	12/24	60X2	
● QOM-60/100	120 / 277	1.48 / .64	50/60	12/24	60/100	
● QOM-60/150	120 / 277	1.93 / .84	50/60	12/24	60/150	
● QOM-60/300	120 / 277	3.28 / 1.42	50/60	12/24	60/300	
● QOM-100	120 / 277	.92 / .40	50/60	12/24	100	
● QOM-100X2	120 / 277	1.84 / .80	50/60	12/24	100X2	
● QOM-100/150	120 / 277	2.29 / .99	50/60	12/24	100/150	
● QOM-100/300	120 / 277	3.64 / 1.58	50/60	12/24	100/300	
● QOM-150	120 / 277	1.37 / .59	50/60	12/24	150	
● QOM-150X2	120 / 277	2.74 / 1.19	50/60	12/24	150X2	
● QOM-150/300	120 / 277	4.09 / 1.77	50/60	12/24	150/300	
● QOM-300	120 / 277	2.72 / 1.18	50/60	12/24	300	
● QOM-300X2	120 / 277	5.44 / 2.36	50/60	12/24	300X2	
● QOM-500	120 / 277	4.48 / 1.94	50/60	12/24	500	
● QOM-600	120 / 277	5.32 / 2.30	50/60	12/24	600	
● QOM-750	120 / 277	6.58 / 2.85	50/60	12/24	750	

CAUTION: USE ONLY WITH MAXIMUM OUTPUT LOAD PER ABOVE TABLE. This product must be installed in accordance with the applicable installation code by a person familiar with the construction and operation of the product and the hazards involved.

- SUITABLE FOR USE WITH SUBMERSIBLE LUMINAIRES OR SUBMERSIBLE PUMPS
- SUITABLE FOR WET LOCATIONS
- WALL MOUNT ONLY
- FOR SUPPLY CONNECTIONS USE WIRE RATED FOR AT LEAST 60 C.
- SUITABLE FOR INDOOR OR OUTDOOR USE
- SUITABLE FOR MOUNTING WITHIN 1.2m (4 ft.) OF THE GROUND
- ISOLATION TOROIDAL TRANSFORMER
- DIMMER, IF USED, MUST BE A MAGNETIC LOW-VOLTAGE DIMMER.
- 50/60 CYCLE A.C. ONLY
- MADE IN THE U.S.A.
- KEEP ENCLOSURE COVER CLOSED
- READ INSTALLATION INSTRUCTIONS BEFORE WIRING

LOW VOLTAGE LUMINAIRE POWER SUPPLY CENTER

CLASS: 120V/277V
 QOM Series tested to:
 UL-2108, UL-1838 3425 81
 CSA C22.2 NO. 250.0-08 3425 15
 CSA C22.2 NO. 250.7-07 3425 95



WARNING: RISK OF FIRE. IF INSTALLATION INVOLVES RUNNING WIRE THROUGH A BUILDING STRUCTURE, SPECIAL WIRING METHODS ARE NEEDED. CONSULT A QUALIFIED ELECTRICIAN.

LISTED



5F78

LOW VOLTAGE LIGHTING POWER SUPPLY CENTER

- LANDSCAPE LIGHTING POWER UNIT
- SUITABLE FOR WET LOCATION
- SUITABLE FOR INDOOR/OUTDOOR USE
- UL 1838 & 2108 LISTED
- ISOLATION TOROIDAL TRANSFORMER
- USE DIMMERS RATED FOR MAGNETIC LOW VOLTAGE LOADS
- 50/60 CYCLE
- MADE IN THE U.S.A.